

ATU HF-SSB Automatic Antenna Tuner 1.6-30 MHz, 125 W

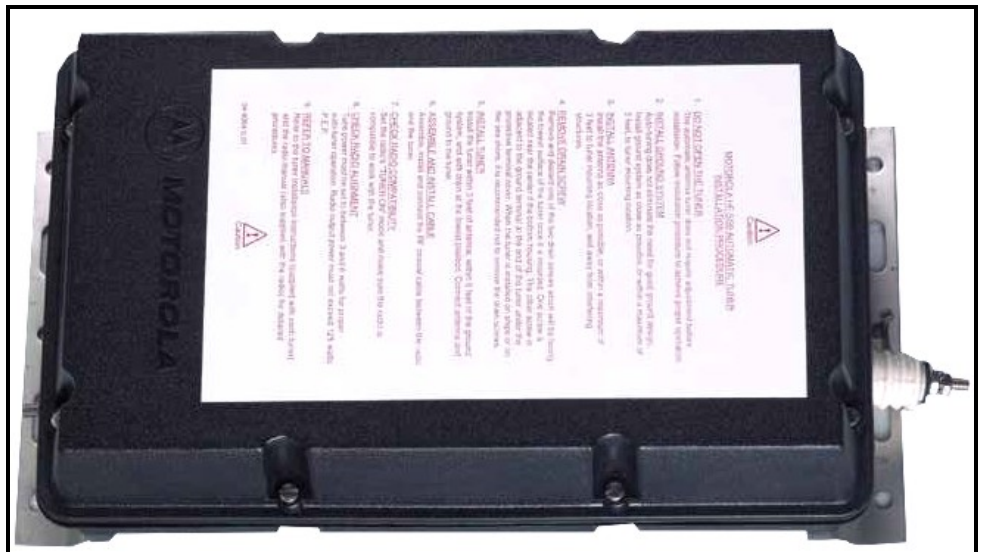

Owner's Manual

68P02948C35-A

ATU
HF-SSB Automatic Antenna Tuner
1.6-30 MHz, 125 W

Owner's Manual

68P02948C35-A

ATU
HF-SSB Automatic Antenna Tuner
1.6-30 MHz, 125 W

TABLE OF CONTENTS

<u>Para.</u>	<u>Page</u>
Performance Specifications	iii
Model Complements	v
Accessories	v
 CHAPTER 1 DESCRIPTION	
1.1 GENERAL DESCRIPTION	1-1
1.2 FUNCTIONAL DESCRIPTION	1-1
 CHAPTER 2 INSTALLATION	
2.1 GENERAL	2-1
2.2 RECOMMENDED EQUIPMENT	2-1
2.2.1 Tools	2-1
2.2.2 Accessories	2-1
2.3 MOBILE INSTALLATION INSTRUCTIONS	2-1
2.3.1 Cable Kits	2-1
2.3.2 Installation Instructions	2-1
2.3.3 Operational Check	2-3
2.4 BASE STATION INSTALLATION INSTRUCTIONS	2-4
2.4.1 Antenna Installation	2-4
2.4.2 Antenna Ground Plane	2-5
2.4.3 ATU Installation Instructions	2-6

TABLE OF CONTENTS (Cont.)

<u>Para.</u>		<u>Page</u>
CHAPTER 3 THEORY OF OPERATION		
3.1	FUNCTIONAL DESCRIPTION.....	3-1
3.1.1	ATU Function	3-1
3.1.2	ATU Operation	3-1
3.2	BLOCK DIAGRAM DESCRIPTION	3-2
3.2.1	RF Matching Network.....	3-2
3.2.2	RF Sensor.....	3-2
3.2.3	Tuner Logic.....	3-2
3.2.4	Latches and Relay Drivers	3-3
3.3	DETAILED CIRCUIT DESCRIPTIONS	3-3
3.3.1	RF Sensor Circuit.....	3-3
3.3.2	RF Matching Network Circuit	3-4
3.3.3	Tuner Logic Circuit.....	3-5
3.3.4	Latches And Relay Drivers Circuit.....	3-6

PERFORMANCE SPECIFICATIONS

ELECTRICAL

Frequency Range	1.6-30 MHz
Input Power Capability	125 W (two-tone test method and a single tone transmission for CW Morse code, both at a duty cycle of 1 minute transmission/4 minutes reception)
Tuning Accuracy	Automatically tunes to 50 Ω with a nominal VSWR of 1.5 (maximum VSWR of 2) on any frequency in the 1.6-30 MHz range
Number of Memory Channels	4437
Tuning Time	Typical: 0.5 seconds Maximum: 3 seconds From memory: less than 300 milliseconds
RF Tuning Power	5-7 W
Antennas	For frequency range 1.6-30 MHz: <ul style="list-style-type: none">- 12 ft (3.7 m) to 16 ft (5 m) mobile whips- 23 ft (7 m) to 35 ft (10.8 m) base station whips- 23 ft (7 m) to 60 ft (18.2 m) long wire antennas For frequency range 2-30 MHz: <ul style="list-style-type: none">- Same as for 1.6-30 MHz plus 8-12 ft (2.5-3.7 m) mobile whips
Power Requirements	12 V dc nominal, 1.2 A, supplied through the RF coax cable from the radio

GENERAL

Environmental Conditions

Vibration	MIL-STD-810D Method 514.3 and EIA RS152B
Shock	MIL-STD-810D Method 516.3 and EIA RS152B
Sand & Dust	MIL-STD-810D Method 510.2
Rain	MIL-STD-810D Method 506.2
Salt Fog	MIL-STD-810D Method 509.2
Operating Temperature	-30°C to +60°C
Storage Temperature	-40°C to +85°C
Humidity	90 to 95% @ 50°C
Dimensions (H x W x L)	14.2" x 3.6 x 9" (36 cm x 9.1 cm x 22.9 cm)
Weight	5.5 lbs (2.5 kg)
Lead-in Length from Antenna to Tuner	1 ft max. (mobile installation)

Specifications subject to change without notice

MODEL COMPLEMENTS

Model F2265A

FLN2301	Mobile Automatic Antenna Tuner (ATU) 125 W
FHN5914	Housing
FLN8372	Antenna Tuner Board
FHN5760	ATU Assembly
FKN4314	High Voltage Cable Kit (for Use with Mobile Whips)
FKN4589A	RF Coax Cable Kit, 17 feet
68P02948C35	ATU, HF-SSB Automatic Antenna Tuner Owner's Manual

ACCESSORIES

FKN4612A	RF Cable kit, 30 feet (N Type - UHF)
FKN4613A	RF Cable Kit, 100 feet (N Type - UHF)

CHAPTER 1

DESCRIPTION

1.1 GENERAL DESCRIPTION

The HF-SSB Automatic Antenna Tuner Unit (ATU) model F2265A is an antenna matching network that provides efficient RF power transfer from the radio system to the antenna.

The ATU handles up to 125 watts Peak Envelope Power (PEP). It is used for voice and Continuous Wave (CW) Morse code communications.

ATU F2265A matches the antenna impedance to the 50 Ω output impedance of the radio system, with a nominal VSWR of 1.5 in the 1.6 to 30 MHz frequency range.

The ATU is housed in a weatherproof case, allowing outdoor installation, such as open roofs.

1.2 FUNCTIONAL DESCRIPTION

The F2265A Automatic Antenna Tuner (ATU) operates in the 1.6 to 30 MHz frequency range at 125 watts peak envelope power (PEP). The ATU automatically selects the network component for the antenna matching, thus eliminating the need for programming, presetting, manual tuning and adjustment during the installation and the operations.

A microprocessor circuit checks the antenna matching each time the channel is changed and then automatically switches inductors and capacitors in and out of the matching network. The tuning data for a given channel is stored in a memory and kept as long as the ATU is on. The next time the channel is used, the stored tuning data for that channel is used, considerably reducing the tuning time (provided that the VSWR is within the specified limits).

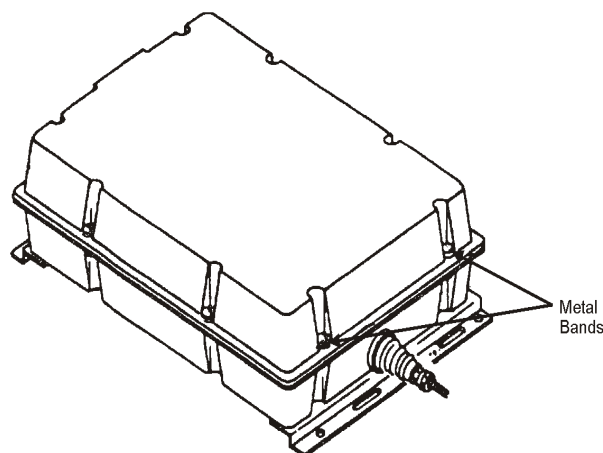

Figure 1-1. ATU General View

CHAPTER 2

INSTALLATION

2.1 GENERAL

The radio and ATU are factory-preset for proper tuning operation and require no additional adjustment or programming.

2.2 RECOMMENDED EQUIPMENT

2.2.1 TOOLS

- Nut driver 7/16" (VACO S-14, USA)
- Nut driver 5/16" (VACO S-10, USA)
- Flat blade screwdriver 7/16"

2.2.2 ACCESSORIES

For mobile installations:

FKN4314	High voltage cable kit (supplied with the ATU)
FKN4589	RF coax cable (supplied with the ATU)

For base station installations:

FKN4314	High voltage cable kit (supplied with the ATU)
FKN4612	30 ft cable kit
FKN4613	100 ft cable kit

2.3 MOBILE INSTALLATION INSTRUCTIONS

2.3.1 CABLE KITS

The ATU basic model is supplied with the FKN 4314 High Voltage Cable Kit and the FKN4589 RF coax cable kit. A special RF Choke is incorporated in the RF cable assembly to eliminate grounding problems.

2.3.2 INSTALLATION INSTRUCTIONS

NOTE

The installation instructions included in the label on the unit cover apply to base station installation. Disregard these instructions in case of a mobile installation.

2.3.2.1 Antenna and ATU Location

The antenna and ATU locations on a vehicle are the most critical parts of a mobile installation, since they have a great influence on the effective radiated power.

2.3.2.1.1 Antenna Location

The ATU tunes mobile whip antennas as specified in the PERFORMANCE SPECIFICATIONS section. However, 15 foot whip is recommended for best efficiency.

For short range communications (ground waves), a vertical (non-bent) antenna is preferred. For long range communications (sky waves), a bent antenna is preferred. The antenna may be bent and tied down to the vehicle's body with a nylon cord.

The best antenna location is the vehicle's rooftop, where the antenna is not obstructed by metal objects. Roof center installation provides good symmetrical-omnidirectional radiation patterns.

If roof top installation is impossible, a side wall installation, with the antenna as far away from the side wall and as high as possible, will suffice.

If the antenna's height above ground is limited, it is preferred to install the antenna as high as possible and to bend and strap it down to the required height (as opposed to installing the antenna close to the ground, such as in a bumper mounted installation).

Installation

The suggested mobile installations are illustrated in Figure 2-1.

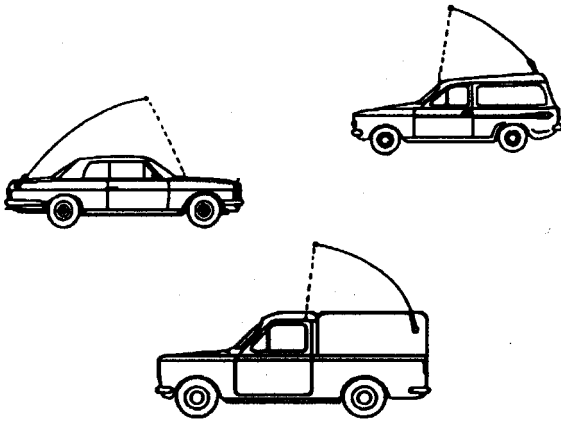

Figure 2-1. Suggested Mobile Installations

2.3.2.1.2 ATU Location

The ATU should be mounted in a location, where the ATU output (antenna) connector is as close as possible to the antenna input connector.

The maximum allowed lead-in wire length is 30 cm. Any reduction in the lead-in wire length improves the system performance. A 10 cm wire ensures good radiation results.

Examples of effective installations are given in Figure 2-2.

NOTE

If installation restrictions exist, the ATU may be installed on the vehicle's exterior.

IMPORTANT

A properly installed ATU adds noise immunity to the radio system.

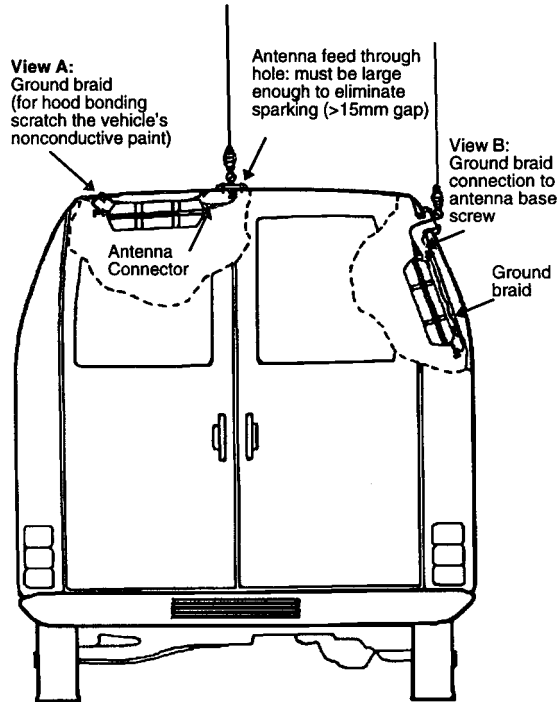

Figure 2-2. Effective Installations

2.3.2.2 Antenna ATU Interconnections

2.3.2.2.1 Whips Longer than 16 ft and Wire Antennas

Step 1. Connect the ATU output connector to the antenna connector with the shortest wire possible. A 12 AWG insulated wire is sufficient for this purpose. The lead-in wire should have about 3" of clearance from metal walls, grounding braids, etc. You may use the FKN4314A High Voltage Cable Kit supplied with the ATU.

Step 2. Connect the ATU ground terminal to the vehicle body with a wide grounding braid, as shown in Figure 2-2, view A. Ensure that the grounding braid is as short as possible. If the ATU is installed on the inner side of the vehicle's body (see Figure 2-2, view B), a second grounding braid should be placed beneath the ATU and connected to one of the bolts securing the antenna base.

2.3.2.2.2 16 ft or Shorter Whips

When connecting a 16 ft or shorter whip to the ATU, you must use the high voltage cable kit FKN4314A supplied with the ATU.

NOTE

It is recommended to shorten the high voltage cable as much as possible, providing that the distance between the antenna base and the ATU is short enough. Use the appropriate ring lug, provided separately in the kit, to reassemble the shortened cable.

Step 1. Attach the high voltage cable conductor to the ATU RF output (see Figure 2-3). While holding the high voltage cable, push the rubber yoke cover until it slips on the yoke.

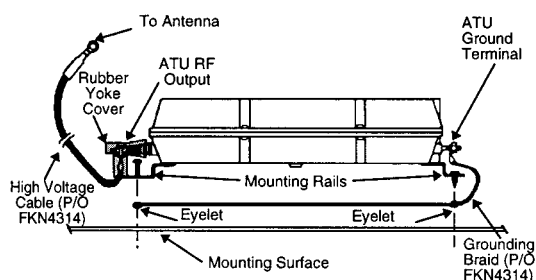

Figure 2-3. FKN4314A High Voltage Cable Attachment

Step 2. Attach the grounding braid of the high voltage cable kit to the ATU ground terminal (see Figure 2-3).

Step 3. Route the grounding braid between the ATU mounting rails and the mounting surface. Align the grounding braid eyelets with the holes in the mounting rails and mount the ATU using the tapping screws provided (see Figure 2-3).

Step 4. If the grounding braid does not provide a good ground to the vehicle's body, connect the supplied grounding wire between the ATU ground terminal and a good grounding point near the antenna base using the supplied tapping screw and split washer.

Step 5. Attach the other end of the high voltage cable to the antenna base.

2.3.2.3 Cable Interconnections

Step 1. Route the RF cable between the ATU and the radio.

Step 2. Connect the RF coaxial cable to the ATU's RF input.

Step 3. Connect the RF cable to the radio.

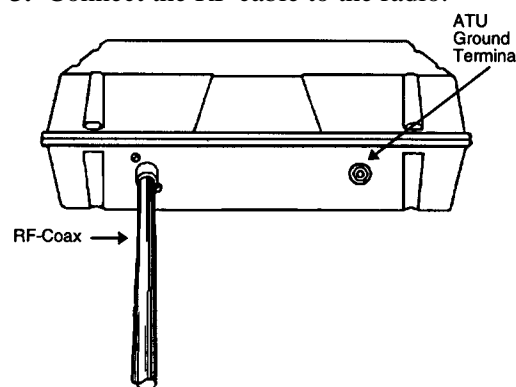

Figure 2-4. ATU Electrical and Mechanical Connections

Step 4. Perform the operational check given in paragraph 2.3.3.

2.3.3 OPERATIONAL CHECK

When the system installation is completed, perform the following operational check:

Step 1. Install an in-line wattmeter between the radio and the ATU.

Step 2. Turn on the radio.

Step 3. Key the radio and whistle into the microphone; observe the forward and reverse power reading on the wattmeter. The forward power should be at least three times greater than the reverse power.

Step 4. Perform step 3 for each channel used.

2.4 BASE STATION INSTALLATION INSTRUCTIONS

2.4.1 ANTENNA INSTALLATION

The recommended length of antennas for base stations is 23 to 60 feet for long wire antennas and 23 to 35 ft for whips, in the specified frequency range. Shorter antennas are recommended for mobile installations only.

2.4.1.1 23 to 35 Feet Whip Antennas

23 to 35 feet whip antennas are suitable for medium to long-range communications. The antenna should be located away from interfering structures, such as metal masts, building and metal wires parallel to the antenna. The distance from these interfering structures should be about one wavelength (see footnote below) of the lowest frequency used.

2.4.1.2 23 to 60 Feet Wire Antennas

The wire antenna can be installed in one of the following configurations: inverted "L," and sloping wire, as illustrated in Figure 2-5 and Figure 2-6.

The antennas illustrated in these figures are suitable for systems using frequencies below 5 MHz. Optimum antenna performance is achieved when the antenna is approximately a quarter of a wavelength long (see footnote below).

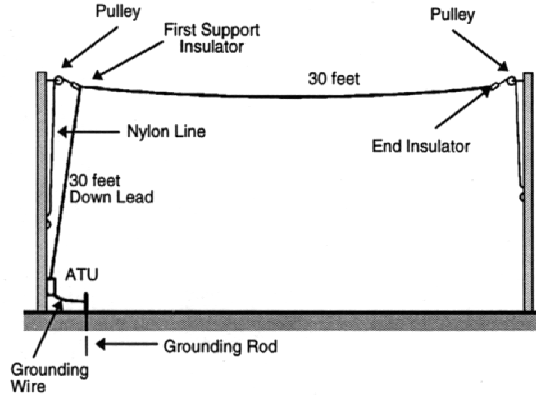

Figure 2-5. Inverted "L" Antenna

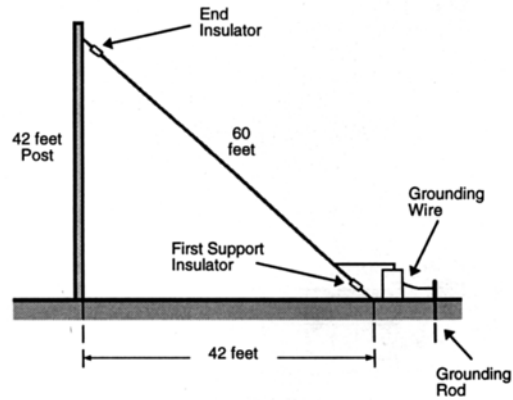

Figure 2-6. Sloping Wire Antenna

If the lowest used frequency is higher than 5 MHz, a good practice is to shorten the overall antenna length to approximately a quarter of a wavelength with the configuration and the wire length ratio as in Figure 2-5 and Figure 2-6.

For antenna length computational purposes only, the following formulas may be used for calculating the wavelength:

$$\text{Wavelength (m)} = \frac{285}{f(\text{MHz})}$$

$$\text{Wavelength (ft)} = \frac{935}{f(\text{MHz})}$$

If the system uses frequencies ranging between f_1 and f_2 , a satisfactory antenna length is a quarter of a wavelength of the mean frequency, where:

$$f_{\text{mean}} = \sqrt{f_1 \times f_2}$$

2.4.2 ANTENNA GROUND PLANE

2.4.2.1 General

The ground plane provides an RF current return path for the antenna. For efficient operation, the loss resistance in the ground must be small in comparison to the antenna radiation resistance. Furthermore, the effective length of the ground system largely affects the shape of the antenna radiation pattern. A poor ground will cause an otherwise good radio to perform poorly.

This section provides a description of a ground plane and explains its installation.

2.4.2.2 Location

A good ground plane must be spread out with the antenna located normally in the center.

2.4.2.2.1 Ground Plane for Whip Antennas

(23 to 35 feet, 7 to 11 meters, non-roof mounted)

12 radials, 35 to 60 feet long, form an adequate ground plane (see Figure 2-7). The 60 feet radials are used for the longer communication ranges. A ground rod should be driven into a ground near the base of the antenna to provide a lightning discharge pass.

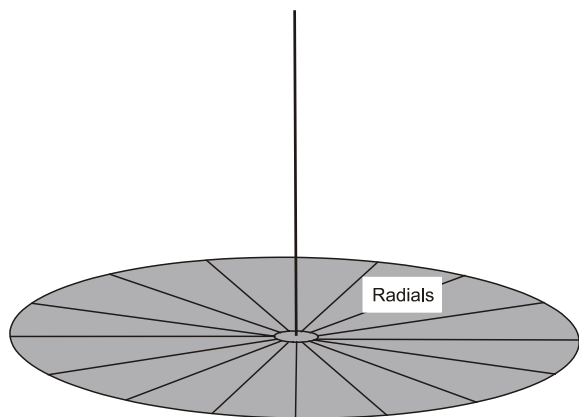
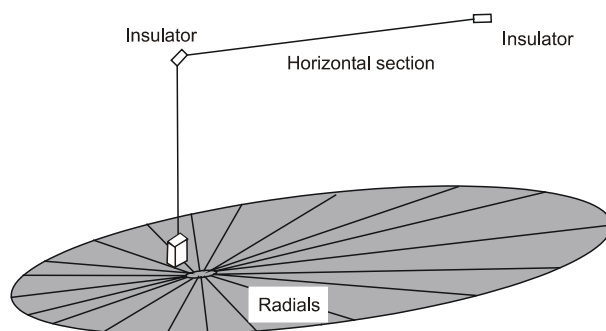

Figure 2-7. Practical Ground Plane for a Whip Antenna

2.4.2.2.2 Ground Plane for Wire Antennas (non-roof mounted)

Twelve radials, 35 to 60 feet long, will form a good ground plane. A ground rod should be driven into the ground close to the antenna base to provide a lightning discharge pass.

The ground plane shape for an Inverted "L" wire antenna should be distorted with most of the surface area placed under the antenna (see Figure 2-8). The sloping wire antenna should have a circular ground plane shape with the antenna feed point at the center.



a. Side View

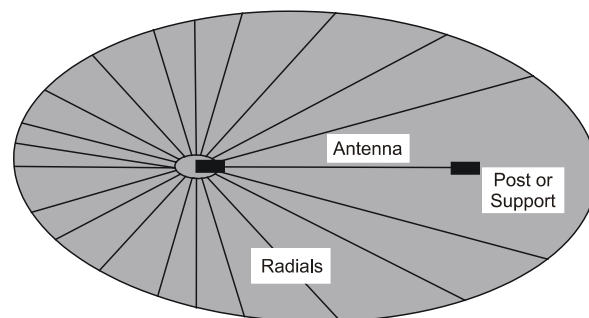

b. Top View

Figure 2-8. Ground Plan for Inverted "L" Wire Antenna

2.4.2.2.3 Ground Plane for Roof Mounted Whips and Wire Antennas

A fairly effective ground can also be achieved by grounding to the building structures or metal roof (see Figure 2-9), provided that the roof pieces are electrically bound together. Antennas far from earth on insulated structures require a ground plane (or radial system).

Two or four radials cut to a quarter or half wavelength for each frequency used ($3/8 \times$ wavelength is a fair optimum) form an effective ground plane above 7 MHz. Below 7 MHz, the required length gets unreasonably long; however, more than four radials 30 to 70 feet (9.1 to 21.3 m) long are recommended. A direct connection to a ground rod driven into the earth,

Installation

or a connection to a water pipe of the building, is required for lightning protection.

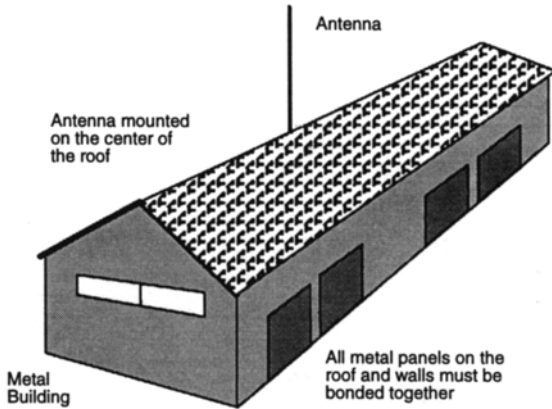

Figure 2-9. Practical Ground Using a Metal Building

2.4.3 ATU INSTALLATION INSTRUCTIONS

Step 1. Locate the ATU as close as possible to the antenna and close enough to the ground system so that the ground lead is less than 5 ft (1.5 m).

Step 2. Attach the ground braid of the high voltage cable kit to the ATU ground terminal (see Figure 2-3).

Step 3. If a wire antenna is used, connect it directly to the ATU RF output terminal. Use mechanical strain relief similar to the one shown in Figure 2-10.

Step 4. Connect the shortest possible ground lead between the antenna ground plane and ATU ground terminal. The base station ground, ATU ground and the antenna ground plane must be bonded to the earth ground.

CAUTION

Do not install the ATU without the earth ground. The earth ground is required both for the ATU efficient operation and for lightning protection.

Step 5. Route the RF coaxial cable between the ATU and the radio.

Step 6. Connect the RF coaxial cable to the ATU's RF input.

Step 7. Connect the RF cable to the radio.

Step 8. Perform the operational check given in paragraph 2.3.3.

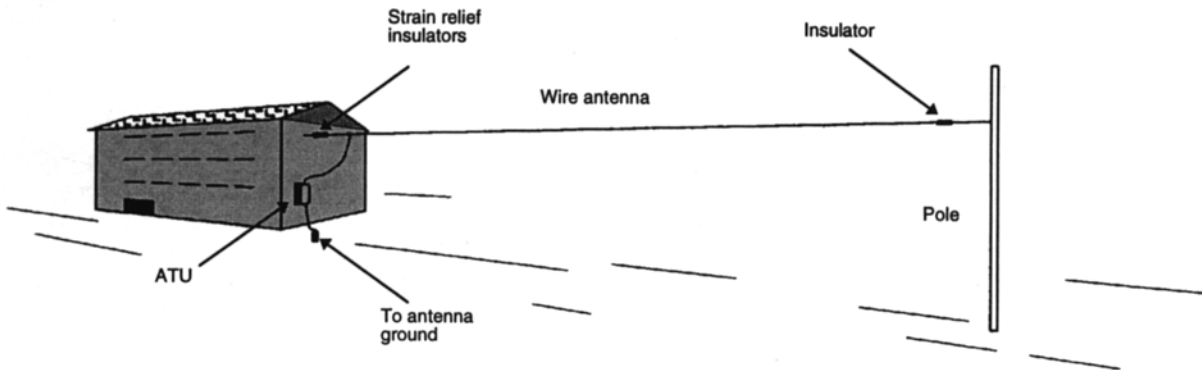

Figure 2-10. Typical Base Station Installation Using a Wire Antenna

CHAPTER 3

THEORY OF OPERATION

3.1 FUNCTIONAL DESCRIPTION

3.1.1 ATU FUNCTION

The ATU allows for an effective energy transfer between the radio and the antenna. This is basically achieved by meeting the following requirements:

- Minimizing the *insertion loss* of the matching network.
- Preventing *mismatch losses* by presenting appropriate impedances to the radio power amplifier and the antenna.

3.1.2 ATU OPERATION

The DC power is supplied to the ATU via the RF cable.

After changing the frequency, the radio interrupts the DC power supply via the RF cable for about 50 milliseconds. After the power returns, the ATU performs the power-on tuning process. During the power interruption, a special backup power is supplied to the tuning data storage, to prevent data loss.

The Tuning Process: When the DC power returns (50 msec after changing the frequency), the Tuner Control circuit (which initiates and controls the ATU operation) turns on. The tuner control circuit sends a signal to the radio to generate an output signal at a tune level (3-6 W) and starts the tuning process.

First, the ATU verifies that the tune power at its input (V-FORWARD) is within the predefined range (3-6 W). Power above this range can damage the relays during the Hot Switching, while power below the predefined range can cause inaccurate tuning.

If the tune power is within the specified range, the ATU captures a 20ms sample of the signal. The sample signal frequency is divided by 128 and measured by a counter. Based on the above data, the frequency measurement resolution is as follows:

$$\text{Resolution} = \frac{1}{20\text{ms}} \times 128 = 6400\text{Hz}$$

The ATU reads the tuning data corresponding to the measured frequency from its internal memory (such data exists if tuning was previously performed for this frequency). The ATU sets the tuning network according to that data and measures the resulting VSWR. If $\text{VSWR} < 2$ the tuning is completed. If it is higher, a new tuning cycle is started.

The tuning process principle is based on crossing the $G=1$ circle in the positive part of the Smith Chart using a series inductance, and then moving towards $\text{VSWR}=1.5$ using a parallel capacitance at the input.

When the ATU completes the tuning process, it stores the tuning network data in memory in a location corresponding to the current frequency.

After the tuning process is completed, the ATU shorts its sensor terminals to ground to protect them from high power, and its microprocessor enters an idle state to prevent noise from the receive channel. The relays' state is maintained by using latches on the relay control lines.

Radio Switching out of TUNE Mode: A sensor in the radio measures the reflected power at the radio output every 100ms. If this power is stable and low enough over a period of 300ms, the radio will switch out of TUNE mode assuming that the tuner has completed the tuning. If the tuning has not been completed after 3 seconds, the radio will automatically switch out of TUNE mode.

3.2 BLOCK DIAGRAM DESCRIPTION

The ATU block diagram is shown in Figure 3-1 and described in the following sections.

3.2.1 RF MATCHING NETWORK

The RF signal from the radio is applied to the RF Matching Network via the RF Sensor. The RF matching network is a combination of inductors and capacitors. The ATU changes the network parameters by switching the inductors and capacitors in and out of the network.

The quality of the network and its components determines the effectiveness of the energy transfer between the radio and the antenna. Therefore, the network components have high-Q (quality factor) and the tuning algorithm is very sophisticated.

3.2.2 RF SENSOR

The RF sensor samples the RF signal, converts the samples to analog levels (between 0-5 V) and transfers the data to the Tuner Logic. The following data is provided on the RF signal:

- PH-L and PH-C signals indicate whether the load is inductive or capacitive.
- V_g signal indicates on which G circle on the Smith Chart the load is located ($G = \frac{1}{R}$).

- V_f signal indicates the forward power.
- V_r signal indicates the reverse power.
- An RF sample for calculating the signal frequency.

3.2.3 TUNER LOGIC

The Tuner Logic circuit performs the following functions:

- Detects channel change in the radio (based on DC interrupting on the RF cable while the channel is changed).
- Calculates the frequency of the RF signal sample provided by the RF sensor.
- Controls the tuning process: it implements the tuning algorithm and sends commands to the relay drivers that control the matching network components.
- Stores the tuning state for each frequency.
- Shorts the RF sensor outputs to the ground after completing the tuning process. This grounding is required for protecting the Tuner Logic circuits and the sensor components from high power during the normal radio transmission.

When the tuning is completed, the Tuner Logic circuit deactivates the relay control commands and enters an idle state.

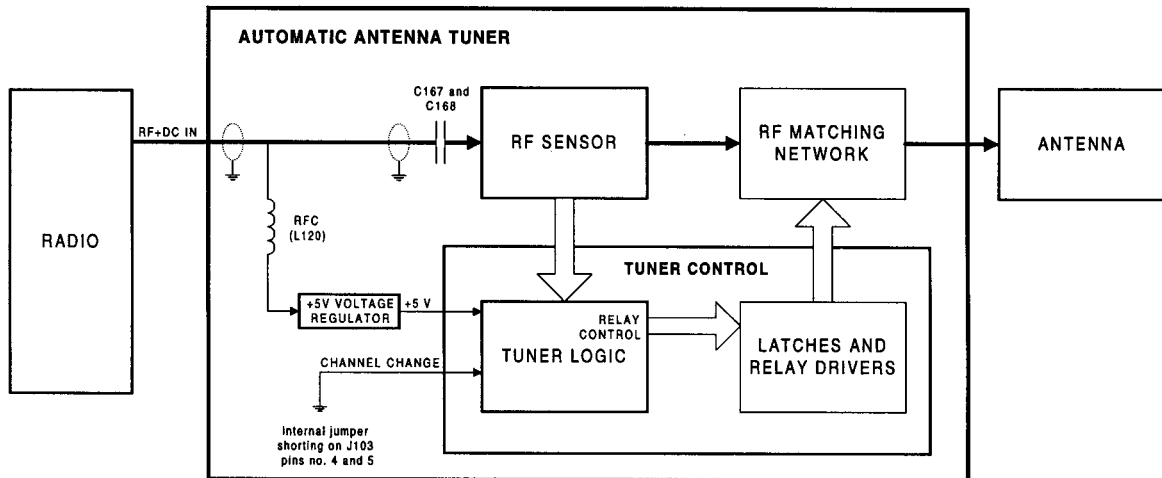

Figure 3-1. ATU Block Diagram

3.2.4 LATCHES AND RELAY DRIVERS

The Latches and Relay Drivers control the components of the matching network. The relay drivers activate the RF relays that switch inductors and capacitors in and out of the network. The latches keep the relays activated after the tuning has been completed and the relay commands have been removed.

3.3 DETAILED CIRCUIT DESCRIPTIONS

Throughout the detailed circuit description you are referred to the Antenna Tuner Board.

3.3.1 RF SENSOR CIRCUIT

The RF input is applied to transformer T101 via connector J101. T101 includes two current transformers, each of which generates a sample of the RF input, as follows:

- One sample is used for sensing the phase of the input signal.
- The other sample is used for sensing the V_g , V_f and V_r (the G circle in the Smith Chart, forward power and reverse power, respectively).

3.3.1.1 Phase Sensor

The phase sensor measures the phase difference between the input signal voltage and the input signal current. A capacitor network made up of C204, C203 and C184 samples the voltage. The voltage sample is applied to pin 6 of the T101 phase sensing transformer and is thus added to the current sample generated in the transformer. Pin 7 of T101 provides a vector sum of the input signal voltage and current, while pin 5 provides the vector difference.

Both outputs are applied to peak detectors (one is made up of CR101, R108, R112 and C132, and the other is made up of CR102, R109, R113 and C133). The peak detectors generate DC voltages PH-C and PH-L, which are proportional to the amplitudes of the above mentioned vector sum and vector difference. The input signal phase characteristics is determined as follows:

- If $PH-C > PH-L$, the input signal has capacitive characteristics.
- If $PH-C < PH-L$, the input signal has inductive characteristics.

3.3.1.2 V_f and V_r Sensor

3.3.1.2.1 General

Voltage representing the forward power (V_f) is derived by vector addition of appropriately scaled samples of the Total RF Current (I_t) and Total RF Voltage (V_t).

Voltage representing the reverse power (V_r) is derived by vector subtraction of appropriately scaled samples of I_t and V_t .

3.3.1.2.2 Detailed Description

The current sample I_t is taken from pins 8 and 9 of T101 and converted to voltage using resistor network R187 through R190. The voltages over resistors R187 + R188 and R189 + R190 have inverted phases.

Two capacitor networks (C192, C193, C205, C206 and C194, C195, C209, C210) provide the V_t samples.

Diodes CR104 and CR105 perform a vector subtraction and addition (respectively) of the V_t and I_t samples.

The V_f and V_r voltages are integrated over resistor and capacitor networks (R104, R111, C123 and R103, R110, C122, respectively) to provide DC voltages representing the absolute values of the V_f and V_r vectors.

The V_f and V_r signals are passed to the Tuner Logic circuit for the VSWR calculation (see paragraph 3.3.3.2).

3.3.1.3 V_g Sensor

As already mentioned, the V_g signal indicates G circle on which the RF signal is located on the Smith Chart.

V_g is derived by vector subtraction of appropriately scaled samples of I_t and V_t signals.

Pins 8 and 9 of T101 provide the current sample (I_t) which is converted to voltage using resistor network R187 and R188. A capacitor network (C199, C207, C208) provides the V_t sample. Diode CR106 performs a vector subtraction of the I_t from V_t . Resistor R102, R107 and capacitor C124 perform integration on the V_g vector to provide a DC voltage proportional to the vector absolute value.

The integrated V_g signal is passed to the Tuner Logic circuit for the G circle indication (see paragraph 3.3.3.2).

3.3.1.4 Frequency Sample

Capacitors C200, C211 and C212 sample the RF signal during the tuning process. Sampling is enabled for a duration of 20 milliseconds under control for the Tuner Logic circuit. The sample signal $FREQ$ is passed to the Tuner Logic circuit.

During sampling, 12 Vdc is supplied to the cathode of pin diode CR108 via R106 and L115 and keeps the diode in the cut off state (the diode does not conduct).

When the sampling is completed the $FREQ_SW$ signal from the Tuner Logic circuit is applied to transistor Q101. The transistor switches on and provides a DC current path from CR108 diode's cathode to ground via R191. Since the diodes' anode receives DC from the Tuner Logic circuit via the $FREQ$ line, the diode now conducts and the RF signal on the $FREQ$ line is shorted to ground via CR108 and capacitor C134.

3.3.1.5 V_{cc} Voltage Supply

Voltage regulator U101 provides the +5 V V_{cc} to the Tuner Logic circuit.

The DC power (typically 13.8 V) is received from the radio via the RF input coaxial cable. This power is interconnected to the 12 V internal power line via RF choke L120.

3.3.1.6 Spark Gap

A 300 V spark gap (E101) protects the radio from high voltage RF or spikes originating in the ATU.

3.3.2 RF MATCHING NETWORK CIRCUIT

Refer to Figure 3-2 for the RF Matching Network Block Diagram.

3.3.2.1 Series Inductor

The network includes a variable series inductor which enables clockwise movement along constant R circles on the Smith Chart, until the $G=1$ circle is crossed towards the inductance side.

The variable inductor is made up of 11 high-Q series inductors, that can be switched in and out of the network using relays connected to each inductor in parallel (K101 - K111). In general, the inductors' values increase in a binary order (except for the L101 and 102 that have identical values, so as to cover the range between 0.08 μ H and 75 μ H).

3.3.2.2 C_{in}

The input capacitor network (C_{in}) enables movement towards the Smith Chart center after crossing the $G=1$ circle.

C_{in} is made up of 26 capacitors (C169-C181, C183, C185-C191, C196-C198, C201, C202) that can be switched in and out of the network using relays K120-K126. C_{in} can accept one of 128 values ranging between 0 pF and 9260 pF.

3.3.2.3 Series Capacitor

The series capacitor (C100, C110) is used either for handling inductive loads or for overcoming high frequency parasitic inductances on the line. The series capacitor can be switched in and out of the network by relay K100.

3.3.2.4 C_{out}

The output capacitor C_{out} (C101-C106) enables matching loads whose impedance real component is above 50 Ω . C_{out} can be switched in and out of the

network by relay K113. C_{out} is most useful in the low frequency range.

3.3.2.5 C_{med}

The function of the variable intermediate capacitor C_{med} (C111 through C117) is identical to that of C_{out} . However, C_{med} is not connected directly in parallel to the antenna and therefore it is more efficient and used instead of C_{out} whenever possible.

C_{med} value ranges between 0 pF and 275 pF in 4 steps under control of two relays (K114, K115). In addition, C_{med} allows tuning inductive loads when the series capacitor (C100, C110) is not sufficient.

3.3.2.6 Bypass Relay (K112)

The bypass relay (K112) is used to bypass output relays K101 through K104 when all of these four relays are closed (inductors L101 through L104 are shorted). This technique improves transfer efficiency, especially at high frequencies.

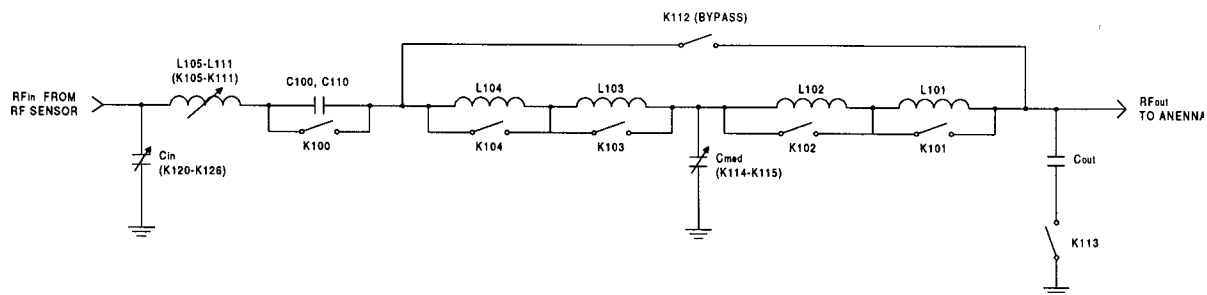

Figure 3-2. RF Matching Network - Block Diagram

3.3.2.7 Relay Activation

A DC power is constantly applied to the relays unless there are 50ms of DC interrupting during channel change. The relays are activated by ground potentials, applied by the Latches and Relay Drivers circuit to the relay control terminals.

3.3.3 TUNER LOGIC CIRCUIT

Refer to Figure 3-1 for the ATU Block Diagram.

The Tuner Logic circuit controls the operation of the Automatic Antenna Tuner. It is based on the 68HC11 microprocessor and performs the following functions:

- Detects channel change and waits for RF tune level from the radio (based on DC interrupting during channel changes).
- Counts the frequency of the RF sample.
- Processes the sensor data and performs the tuning algorithm based on this data.
- Controls the activation of the relay drivers.

Theory of Operation

- Shorts the sensor outputs to the ground after the tuning process is completed.
- Stores the tuning data for each frequency used.
- Keeps the tuning data storage alive after the ATU is turned off for a minimum of 0.5 second (this function is necessary for the 50ms of DC interrupting when the channel is changed).
- Enters idle state after the tuning process is completed and the tuning data is stored. This feature minimizes the noise on the receive path during reception.

3.3.3.1 Frequency Counter

The frequency sample $FREQ$ from the RF Sensor is converted to square wave by U3 and divided by 128 by U15 and U16. The divided signal is applied to the microprocessor input PA7. The microprocessor counts the signal frequency in a 20 millisecond time slot. Therefore the frequency measurement accuracy is 6400 Hz calculated as follows:

$$\frac{1}{20 \cdot 10^{-3} \text{ sec}} \times 128 = 6400\text{Hz}$$

3.3.3.2 Sensor Data Processing

The sensor data is applied to microprocessor inputs PE0 through PE7. An internal A/D converter converts the data into a digital format, in which all the calculations are performed. The following calculations and decisions are done:

- Calculating the VSWR:

$$VSWR = \frac{1 + \frac{V_R}{V_F}}{1 - \frac{V_R}{V_F}}$$

- Calculating the location on the Smith Chart in relation to the $G=1$ circle:
 - if $V_g > V_f$, then $G < 1$;
 - if $V_g < V_f$, then $G > 1$.
- Verifying that the tune power at the ATU input is within the predefined range (3-6 W):
 - if $V_f < V_{low}$ or $V_f > V_{high}$, the tuning request is rejected and the ATU is bypassed.

- Determining the load characteristics:
 - if $PH-C > PH-L$, the load is capacitive;
 - if $PH-L > PH-C$, the load is inductive.

3.3.3.3 Shorting the Sensor Outputs

After the tuning process is completed, the Tuner Logic circuit shorts the signal lines from the sensors to a ground, to protect the logic circuits and the sensor components from high power during normal transmission.

A 100 Ω resistor and a FET switch are connected between the sensor outputs and the ground (R45-R49 and Q27-Q31). A control signal from the microprocessor output PA6 turns on the FET switches.

The signal F_SWITCH generated by the microprocessor at pin PA5 controls the shorting of the frequency sampling circuit in the RF Sensor. Refer to paragraph 3.3.1.4 for a detailed description of the frequency sampling circuit.

3.3.3.4 Tune Data Memory

The Tuner Logic circuit saves the tuning data for each tuned frequency in RAM U9. This data is stored as long as the ATU is on.

3.3.3.5 Relay Driver Activation

The microprocessor controls the relay activation via the SPI BUS serial bus. The serial control data is passed to the Latch and Relay Drivers circuit.

3.3.4 LATCHES AND RELAY DRIVERS CIRCUIT

The relay control data received from the Tuner Control circuit via the SPI BUS, is applied to shift registers U10-U13. The shift registers convert the serial data into parallel. Each shift register provides 8 bits, all of which are combined into a 32 bit parallel bus (DRIVERS_BUS).

The DRIVERS_BUS bits are applied to 26 transistors that actually drive the relays via the RELAY_BUS.